

# Owner's Manual

## MEDIAMASTER 9800 S



**NOKIA**  
CONNECTING PEOPLE

## **Important Information**

### **Wiring the plug (UK and Eire only)**

The mains lead on this product is already fitted with a non-rewireable (moulded) plug incorporating a fuse, the value of which is indicated on the pin face of the plug. Should the fuse need to be replaced, an ASTA or BSI approved BS 1362 of the same rating fuse must be used.

If the fuse cover is detachable, always refit the cover after replacing the fuse. NEVER use the plug with the fuse cover omitted.

If the fitted plug is not suitable for your socket outlets, it should be cut off, after having first removed the fuse, and an appropriate plug fitted in its place. If this new plug contains a fuse, its value should be the same as that removed from the non-rewireable plug.

The severed plug must be destroyed immediately to avoid possible shock hazard.

If you need to replace the mains plug, follow the instructions given below:

The wires in the mains lead are coloured in accordance with the following code: BLUE - Neutral (N): BROWN - Live (L).

As these colours may not correspond with the coloured markings identifying the terminals in your plug, proceed as follows:

The wire coloured BLUE must be connected to the terminal marked with the letter N or coloured BLUE or BLACK.

The wire coloured BROWN must be connected to the terminal marked with the letter L or coloured BROWN or RED.

On no account should either of these wires be connected to the terminal marked E or coloured GREEN or GREEN and YELLOW.

Before replacing the plug cover, make certain that the cord grip is clamped over the sheath of the lead: not simply over the two wires.

If in doubt, consult a qualified electrician.

Nokia Multimedia Terminals operates a policy of continuous development. Therefore we reserve the right to make changes and improvements to any of the products described in this manual without any prior notice.

The EMC Directive 89/336/EEC is applied to this product.  
DiSEqC™ is a trademark of EUTELSAT

Nokia is a registered trademark of Nokia Corporation.

Copyright © 1999. Nokia Multimedia Terminals.  
All rights reserved.

# MEDIAMASTER 9800 S

## Contents

<b>GENERAL OPERATION OF THE MEDIAMASTER</b>	<b>4</b>	<b>VIEWING MODE</b>	<b>20</b>
<b>FOR YOUR SAFETY</b>	<b>4</b>	General Information	20
<b>REMOTE CONTROL</b>	<b>5</b>	Programme Information	20
Rear Panel	6	The "i" (Information) Button	21
Front Panel	6	Guide	21
<b>ABOUT THE SMARTCARD AND CA MODULE</b>	<b>7</b>	List of TV or Radio Channels	22
Pay TV Services with a Smartcard (Viaccess)	7	Options (Green Button)	22
Pay TV Services with a CA Module	7	TV Release (0)	23
<b>INSTALLATION OF THE MEDIAMASTER</b>	<b>8</b>	Video Recording	23
Preparing the Remote Control	8	The TEXT Button (Teletext)	23
Connecting the Mediamaster to the Dish	8	EXIT TV	23
Connecting the Mediamaster to the TV	9	<b>MAIN MENU</b>	<b>24</b>
Connecting a TV and VCR	9	General Information	24
Connecting an Analogue Satellite Receiver and VCR	10	TV and Radio Channels	24
Connecting a HiFi System	10	Edit Channels	24
Switching on for the First Time with SCART Connections	11	System Configuration	29
Tuning Procedure when RF Connections are Used	11	Channel Search	29
<b>FIRST TIME INSTALLATION</b>	<b>12</b>	Antenna/Satellite Configuration	29
General Information	12	TV Settings	30
The Welcome Menu	12	Time Adjustment	30
Language	12	Receiver Upgrade	31
RF Modulator Type	13	Reinstall	31
Antenna/Satellite Selection	13	User Preferences	31
Common Menus	13	Language Preferences	31
Antenna Adjustment and Signal Check	14	Parental Control	32
Line 1 Through 4 on the Antenna Satellite Selection Menu	15	Appearance Preferences	32
Line 5 and 6 on the Antenna Satellite Selection Menu	15	System Information	33
Line on the Antenna Satellite Selection Menu	16	Diagnostics	33
One Antenna/One LNB Configuration	16	Conditional Access	34
Multisatellite/DiSEqC Switch Configuration	17	Viaccess embedded	34
Channel Search	18	Common Interface (CI)	34
Channel Search Progress	19	<b>GLOSSARY OF TERMS</b>	<b>35</b>
Time Adjustment	19	<b>PROBLEM SOLVING</b>	<b>36</b>
		<b>FRONT PANEL DISPLAY</b>	<b>37</b>
		<b>TECHNICAL SPECIFICATIONS</b>	<b>38</b>
		<b>MENU SCREEN STRUCTURE</b>	<b>39</b>

## GENERAL OPERATION OF THE MEDIAMASTER

Throughout this manual you will notice that the everyday operation of your Mediamaster is based on a series of user friendly on-screen displays and menus. These menus will help you get the most from your Mediamaster, guiding you through installation, channel selection, viewing and many other functions.

All functions can be carried out using the buttons on the remote control, and some of the functions can also be carried out using the buttons on the front panel.

If at any time when using the menus (except Installation and Reinstall) you want to return to the normal TV/Radio mode, press the EXIT button.

The Mediamaster is easy to use, always at your command and adaptable for future advances.

Please be aware that new software may change the functionality of the Mediamaster.

Should you experience any difficulties with the operation of your Mediamaster, please consult the relevant section of this manual, including the Problem Solving, or alternatively call your dealer or a customer service adviser.

**Please note:** The first thing to do before sending the Mediamaster to service is to:

**1:** Perform "Diagnostic" procedure in System Information menu.

**2:** Try downloading new software into the Mediamaster.











With this procedure, the new software may solve the problem in the quickest and most efficient way. See the relevant section "Receiver Upgrade" further on in this manual.

## FOR YOUR SAFETY

- **Allow clear space around the Mediamaster for sufficient ventilation.**
- **Do not cover the Mediamaster or place it on a unit that emits heat.**
- Use a soft cloth and a mild solution of washing-up liquid to clean the casing.
- Never allow liquids, spray or other materials to come into contact with the inside of the Mediamaster.
- Do not connect or modify cables when the Mediamaster is plugged in.
- Do not remove the cover.
- Do not allow the unit to be exposed to hot, cold or humid conditions.
- Service should be carried out only at a Nokia Authorised Service Centre.
- Please note that the only way to isolate the Mediamaster completely from the mains supply is to unplug the mains lead!

# REMOTE CONTROL

This section describes how to operate the Mediamaster using the buttons on the remote control. Some of the functions can also be carried out using the buttons on the front panel.

-  To switch the Mediamaster in and out of standby mode.
- EXIT TV**  To return to the viewing mode from a menu without storing settings (in menu mode).  
 To switch between TV or Radio (in viewing mode).
-  To turn the sound off/on (mute).
-  To adjust the volume of digital programmes. The Mediamaster's maximum level is controlled by the TV's present volume setting.
- 0 - 9** To change channel and to select individual menu options. Note: If 0 is entered as the first digit, the TV Release functionality is activated (see below).
- 0**  TV Release. To switch between digital TV/Radio, analogue TV and analogue satellite TV and VCR, when your systems are connected by SCART leads.
- i** Info. To display short and extended information (if transmitted) about current and next programmes.
- BACK** To go back one level in the menus without storing settings.
- TEXT** To select teletext information. Press to enter teletext (if available).
- MENU** To display or exit from the "Main Menu" screen.
- GUIDE** To obtain a list of present and following programmes for the available channels. This information is only shown if your Service Provider transmits programme information (EPG information).
- P+ P-** To change channels up and down by one unit.
-  To change page in a menu/list/text if more than one page is available. To browse through teletext history.
-  To move up/down in the menus and to change channels.
-  To change settings in menus.
- OK** To confirm choices and selection of a highlighted item. To display the TV/Radio channel list.
-  (Red) At the moment, no function.
- OPTION** (Green) To select service options in viewing mode.
- FREEZE** (Yellow) To select the freeze function. Press once to freeze the screen picture. Press any other key to go to normal mode again.
-  (Blue) To toggle between present and previous TV/Radio channels.



## Rear Panel

**Mains lead**  
95-260 V AC  
50-60 Hz

**DIGITAL AUDIO phono connector**  
S/PDIF output for connection to a HiFi system

**AUX SCART**  
for the connection to a VCR, or an analogue satellite receiver

**TV/VCR**  
for an RF-cable to the aerial input of the TV or VCR

**ANTENNA \***  
Satellite dish input (F-connector)

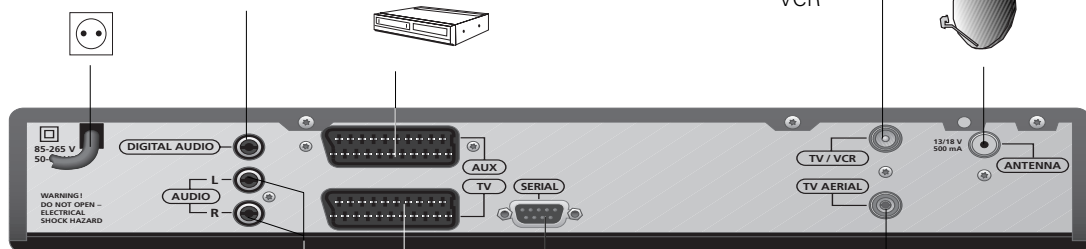

**AUDIO L R phono connectors**  
Stereo outputs for connection to a HiFi system

**TV SCART**  
for the connection to the TV

**SERIAL PORT**  
to read and load data information

**TV AERIAL**  
for a terrestrial (conventional) TV aerial

*\* LNB cable also feeds the LNB with a supply voltage of 13/18 V (V/H polarisation) and a 0/22 kHz signal (bandswitch). Max LNB current 500 mA.*

## Front Panel

**Button**  
for a CA module release

**Display**  
shows channel number, error messages, remote control commands and time in standby mode



**Slot**  
for a Smartcard

**Slot**  
for a CA module with a Smartcard

**Power button**  
to put the Mediamaster in and out of standby mode

**Arrow buttons**  
to move up/down in the menus and to change channels.

## ABOUT THE SMARTCARD AND CA MODULE

To be able to receive scrambled digital satellite channels you will need a Smartcard and/or a Common Interface CA (Conditional Access) module from the Service Provider of your choice.

The Service Provider is the programme distributor.

If you are subscribing to services from more than one Service Provider, you might have to change between different Smartcards and/or CA modules.

Please note that a Smartcard and CA module may only be valid for a single Service Provider and due to this, a specific range of channels.

The Smartcard and the CA module may also provide access to special menus not described in this manual. If so, please follow the instructions from the Service Provider.

Only "free to air" channels are available without the Smartcard and/or the CA Module.

**Note:** The Smartcard and/or the CA module are distributed by your Service Provider.

After inserting the card, leave it in the slot permanently. Do not remove it again, unless your Service Provider asks you to do so. This is important, because if your Service Provider wants to download new information to the Smartcard, the card has to be in the slot.

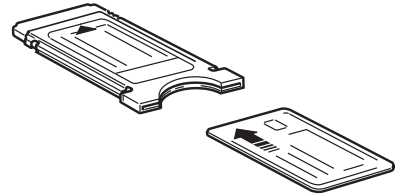
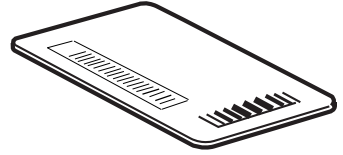

### Pay TV Services with a Smartcard (Viaccess)

**Only for Pay-TV services coded with the Viaccess CA system.**

- Insert your Smartcard fully into the slot behind the lid of the front panel of the Mediamaster. The gold chip should face **downwards and inwards**.



#### **Note 1!**

The gold chip must be on the **underside** of the **smartcard**

### Pay TV Services with a CA Module

- Follow the instructions from your Service Provider concerning the Smartcard and/or CA module.
- Insert the CA module (use only a DVB Standard, Common Interface CA Module) fully into the slot behind the lid of the front panel of the Mediamaster.
- Press the grey button on the front panel if you need to remove the CA module.



#### **Note 2!**

Follow your Service Providers instructions on how to insert the CA module

#### **PIN Code**

The Smartcard is loaded with a 4-digit code, also called a PIN code (Personal Identification Number).

The code is essential in order to access future services offered by the Service Provider.

# INSTALLATION OF THE MEDIAMASTER

The box for your Mediamaster should contain the following items:

- the Mediamaster
- a remote control with 2 AAA batteries
- a SCART lead (fully featured 1,0 metre)
- an aerial/Rf lead (double screened 1,5 metres)
- an Owner's Manual (this document)
- a Software License agreement



## About the SCART sockets

- The rear panel of the Mediamaster is equipped with 2 **SCART** sockets (see diagram). **When you connect other products to any of these sockets, always use fully featured SCART leads** (as supplied). There are "less well specified" SCART leads on the market and picture quality could be reduced if you use them.



## Preparing the Remote Control

- Remove the cover on the battery compartment at the bottom of the remote control.
- Insert the 2 AAA (1,5 V) batteries, as shown in the diagram, taking care to observe the + and - markings indicated inside.
- Replace the cover.

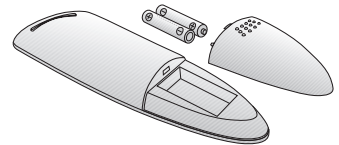

## Connecting the Mediamaster to the Dish

### If you need to fit the F-connectors onto the cable

- Prepare each end of the cable as shown in the diagram. You will need to fold back the outer braid (as shown).
- Slide the F-connector onto the cable, then turn it clockwise until it grips the braid.
- Ensure that 3 mm of the core is protruding from the end of the connector.

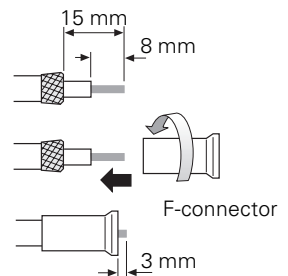

### Installing the Satellite Dish

- See the "Fitting instructions for satellite dish" on how to install the dish.
- Connect the coaxial cable, with F-connectors fitted, from the LNB on the satellite dish to the socket marked "ANTENNA" on the rear panel of the Mediamaster (or e.g. a DiSEqC switch).

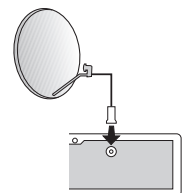

## Connecting the Mediamaster

There are many different types of TV/VCR and other equipment that you can connect to the Mediamaster.

In this manual you will see some of the most common ways to connect your equipment.

If you use RF leads you will have to tune your TV and VCR to the Mediamaster output channel (see page 11).

If you have problems with your connections and need help, contact **your dealer or Service Provider**.

## Connecting the Mediamaster to the TV

### SCART connection

- Do not remove the TV aerial from the TV.
- Connect the SCART lead between the main SCART socket on the TV and the TV SCART socket on the Mediamaster.

### RF connection (dashed line)

- Connect an RF lead from the TV/VCR output on the Mediamaster to the RF input socket on the TV.
- Connect the TV aerial to the TV AERIAL input socket on the Mediamaster.

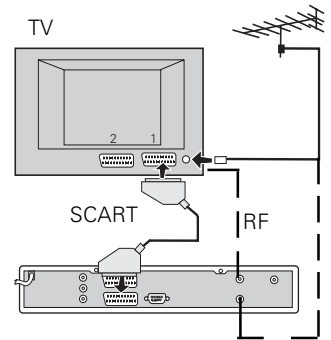

## Connecting a TV and VCR

Refer to your VCR's manual for full instructions.

- Connect one SCART lead between the main SCART socket on the TV and the TV SCART socket on the Mediamaster.
- Connect another SCART lead between the VCR and the AUX SCART socket on the Mediamaster.
- Connect the RF lead from the RF output on the VCR to the TV aerial input on the TV.
- Connect the TV aerial to the RF input socket on the VCR.

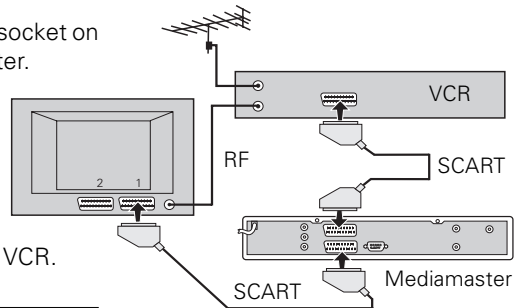

### If your TV has a SCART socket, but your VCR does not

- Connect a SCART lead between the main SCART socket on the TV and the TV SCART socket on the Mediamaster.
- Connect an RF lead from the RF output on the VCR to the TV aerial input on the TV.
- Connect an RF lead from the TV/VCR output on the Mediamaster to the RF input socket on the VCR.
- Connect the TV aerial to the TV AERIAL input socket on the Mediamaster.

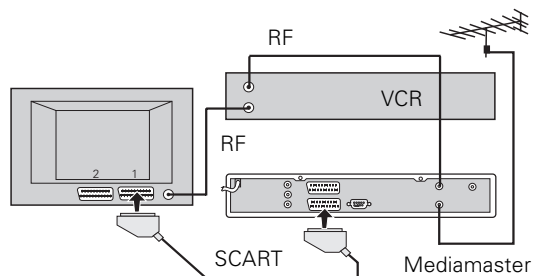

## Connecting an Analogue Satellite Receiver and VCR

- Connect a SCART lead between the main SCART socket on the TV and the TV SCART socket on the Mediamaster.
- Connect a SCART lead between the VCR and the AUX SCART socket on the Mediamaster.
- Connect an RF lead from the RF output on the VCR to the TV aerial input on the TV.
- Connect an RF lead from the RF output on the Analogue receiver to the RF input socket on the VCR.
- Connect the TV aerial to the RF input socket on the Analogue receiver.

*In order to switch the signal from the dish between the analogue and digital receivers, you need a Nokia Smart priority switch (at A B in the diagram) or a Universal Twin LNB.*

### Nokia Smart priority switch

- Connect a coaxial cable between output **A** on the NOKIA Smart priority switch (accessory) to the LNB socket **on the analogue receiver**.
- Connect a coaxial cable between output **B** on the NOKIA Smart priority switch (accessory) to the ANTENNA socket **on the Mediamaster**.

**The analogue receiver must be switched to OFF (standby) when you want to watch digital satellite channels from the Mediamaster.**

### Universal Twin LNB

If you have a Universal Twin LNB you connect:

- Cable A between output **A** on the LNB to the LNB socket **on the analogue receiver**.
- Cable B between output **B** on the LNB to the ANTENNA socket **on the the Mediamaster**.

*Both the VCR and the analogue satellite receiver must be tuned to different UHF channels than the Mediamaster when using RF-connectors.*

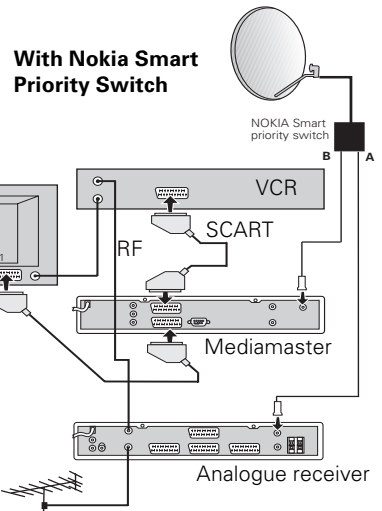

Nokia Smart Priority Switch

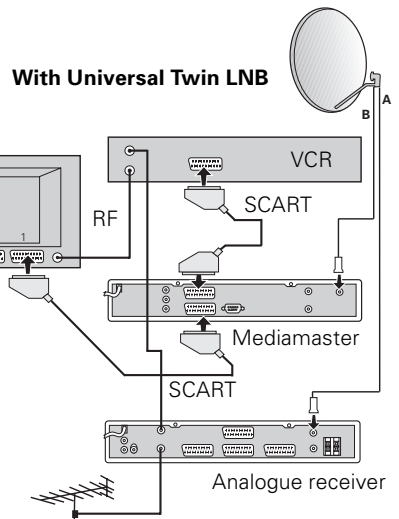

## Connecting a HiFi System

- Connect an RCA/Cinch stereo cable from the AUDIO L R sockets on the Mediamaster to the LINE, AUX, SPARE or EXTRA input sockets on your HiFi system.
- If available you can connect an RCA/Cinch single cable from the DIGITAL AUDIO socket on the Mediamaster to your HiFi or Dolby Pro Logic system.

**Note:** To avoid interference you must use a screened video cable.

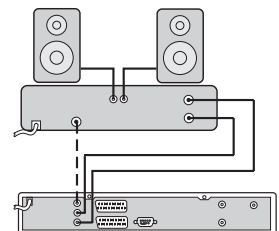

## Switching on for the First Time with SCART Connections

- Plug in your Mediamaster
- Now you will see the "Welcome" menu on the screen.
- Press **OK** on the Mediamaster remote control to start the Installation procedure.

You may now proceed to "First Time Installation."



## Tuning Procedure when RF Connections are Used

**This procedure is necessary only if your Mediamaster is connected to the TV with an RF lead.**

To tune your TV to the RF signal you might also need your TV manual in addition to this manual. The steps below explain what to do if you have been unable to use SCART leads in your connection.

- Plug in your Mediamaster.

### Tuning your TV to the Mediamaster

- Select a channel number on the TV that is not currently used for other TV channels.
- Follow the instructions in your TV manual to tune the TV channel selector to UHF channel 43 (this is the Mediamaster's factory preset UHF channel). If you are already using this channel, select another non occupied UHF channel between 21 to 69 on the TV.
- For example, if you select UHF channel 45 on your TV, you must change your Mediamaster to the same channel. Use the **▼** or **▲** buttons on the front panel of the Mediamaster, or on the remote, to change to the corresponding channel. You will see the UHF channel number displayed on the front panel of the Mediamaster.
- When you have correctly changed the UHF channel number you will see the "Welcome" menu on the TV screen. If there is interference from other channels you will have to change the chosen UHF channel.
- Follow the instructions in your TV manual to store this UHF channel as the channel used by your Mediamaster. You will have to select it when you want to watch digital TV/Radio channels.
- Once the welcome message is visible, press the **OK** button on the Mediamaster remote control to start the installation procedure.

CH 43



*If for some reason you have to change the RF channel later, you can do this by using TV settings menu further on in this manual.*

*If you have a VCR connected it must be tuned to a different UHF channel (between 21 to 69) than the Mediamaster.*

You may now proceed to "First Time Installation."

# FIRST TIME INSTALLATION

## General Information

Once you have correctly connected the Mediamaster, you also have to perform a "First Time Installation." During this procedure, helpful information is displayed at the bottom of the menus.

### Please note!

The **OK** button always **confirms** a selection within these menus, and pressing it will take you to the next step in the installation process. However, and this is important, often more than one value has to be entered in a menu. First, perform all necessary settings on the different lines. Then, confirm them all simultaneously by pressing **OK**.

You can always go back to the previous menu by pressing the **BACK** button.

Use the **▲ ▼** buttons to move upwards and downwards from one line to another. Use **◀ ▶** to change settings.

You can also use the numeric buttons on the remote control to select a line in a menu and to enter numeric values.

## The Welcome Menu

This picture indicates that you have started the installation procedure.

Press the **OK** button to proceed.



## Language

Select the desired menu language.

This will also be the main language for audio and subtitling.

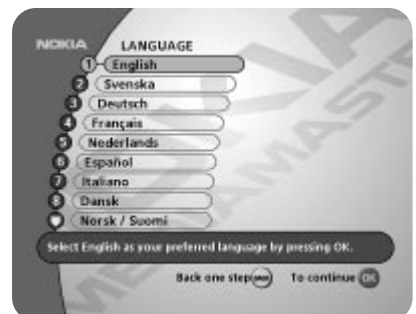

# FIRST TIME INSTALLATION

## RF Modulator Type

If the Mediamaster is connected to the TV with a RF cable, you must select the right RF modulator alternative, which is dependent on the country where the Mediamaster is being used.

Select “**UK (PAL I)**” if this is applicable.

Select “**Other (PAL B/G)**” for all other country alternatives.

If you get picture but no sound, the RF modulator selection might be wrong.

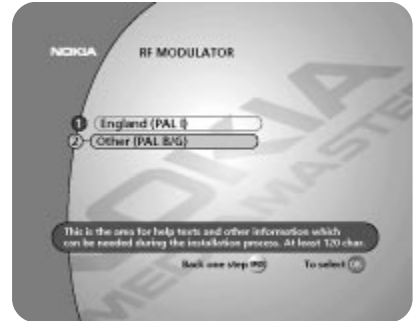

## Antenna/Satellite Selection

Select one of the alternatives from line 1 to 4 if you have a single antenna equipped with one LNB for receiving signals from either ASTRA, HOTBIRD, SIRIUS or THOR.

Select one of the alternatives from line 5 or 6 if you have one antenna with two LNBs or two antennas with one LNB on each for receiving signals from the combination ASTRA/HOTBIRD or SIRIUS/THOR. In these cases you also need a DiSEqC switch.

For any other antenna/LNB combination, select alternative 7.

**Alternatives 1-6 requires the use of a Universal LNB(s)**

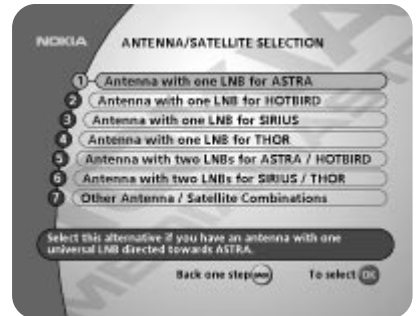

## Common Menus

The Antenna Adjustment description **on the next page** will show you how to proceed from any of the alternatives in the menu above. The procedure may be summarized as:

- First: Adjust the antenna to the right satellite.
- Second: Check the picture quality from a preprogrammed channel.
- Third: Start the Channel Search procedure.

# FIRST TIME INSTALLATION

## Antenna Adjustment and Signal Check

Pressing **OK** from the selected alternative in the previous menu will display the Antenna Adjustment menu (shown to the right) on the screen.

For each satellite, (e.g. ASTRA, HOTBIRD, SIRIUS, THOR), up to 4 different channels are preprogrammed and shown in the menu. When you adjust the antenna, your Mediamaster will use the **marked** channel to find signals from a satellite. (You can select another channel with the ▼ ▲ buttons.)

**1** Adjust the antenna towards the desired satellite until you have a high value on the Signal Strength (AGC) \*) indicator (the red bar at the top of the menu.)

**2** When the antenna is correctly positioned towards the satellite and the signal strength is as good as possible, press **OK**.

If you have found a **digital signal** you should then normally get a picture from the marked channel.

**3** The bar at the top of the menu will now change to a red/yellow/green Signal Quality (SNR) \*) indicator for that specific channel.

If you do not get a picture, you may be tuned to an analogue signal source. Another reason could also be that the antenna is positioned towards the wrong satellite.

Press the **BACK** button and start from point **1** again.

The reason could also be that the marked channel is not transmitting at the moment. Press the **BACK** button and select one of the other preprogrammed channels in the menu with the ▼ ▲ buttons. Then, start from point **2** again.

When you have a picture, press **OK** to go to the "Channel Search Progress" menu, see page 18, from which you now can start to download channels.

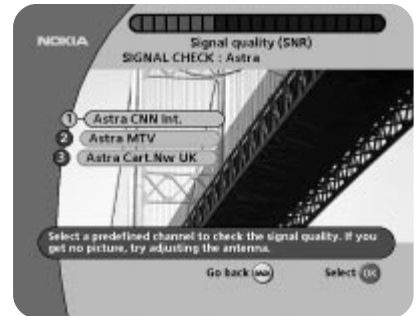
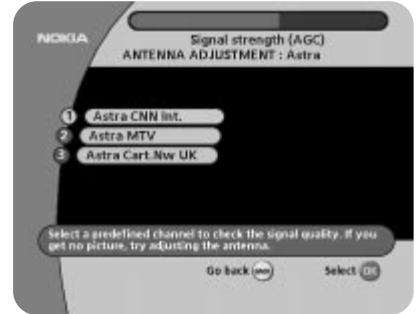

### \*) About Signal Strength (AGC) and Signal Quality (SNR)

The different signal indicators at the top of the menu provide information about two things:

**AGC:** The AGC, shown with a **red bar**, will indicate the average strength of any incoming signal, digital as well as analogue.

**SNR:** When a programme from a satellite channel shows up on the screen, the indicator bar will change from showing AGC to showing SNR. The bar is now **red, yellow and green**, and will indicate the signal quality from that specific channel.

# FIRST TIME INSTALLATION

## Line ① Through ④ on the Antenna Satellite Selection Menu

Select one of the alternatives ASTRA, HOTBIRD, SIRIUS or THOR when you have a single LNB pointed towards any of these satellites.

Then follow the “**Antenna Adjustment and Signal Check**” instructions on the previous page.

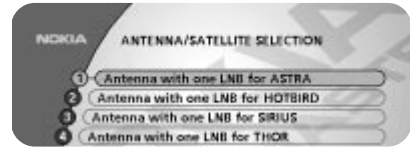

## Line ⑤ and ⑥ on the Antenna Satellite Selection Menu

Select one of these alternatives when you have a single antenna equipped with 2 LNBS, or two antennas with one LNB on each, and want to watch channels from ASTRA/HOTBIRD or SIRIUS/THOR.

In this case you must first connect the LNBS to an external switch since there is only one antenna input on the Mediamaster. Once installed the switch automatically selects the correct LNB for the selected channel.

This external switch is better known as a **DiSEqC™** switch. Since the switch can be located **close to the LNBS**, you only need **one** cable down to the Mediamaster.

### Connection of a DiSEqC switch:

Connect the cable from the LNB intended for channels from ASTRA (or SIRIUS) to the connector marked LNB 1 on the switch, and from HOTBIRD (or THOR) to the connector marked LNB 2. Connect the antenna cable to the connector marked Receiver OUT on the switch. Connect the other end of this cable to the ANTENNA input in the rear of the Mediamaster.

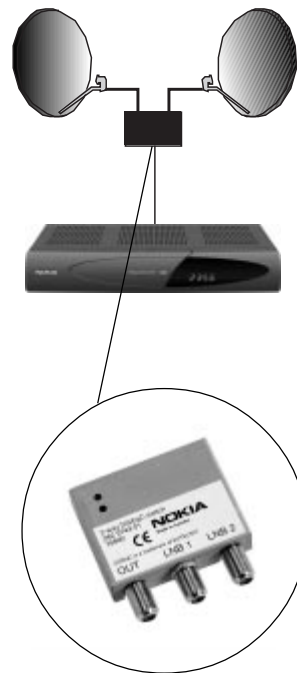
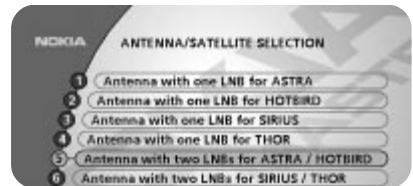

Please follow the instructions on page 14, “**Antenna Adjustment and Signal Check.**”

The difference in this case is that you now will have channel alternatives from two satellites.

Adjust the antenna until the indication value is as good as possible for both satellites.

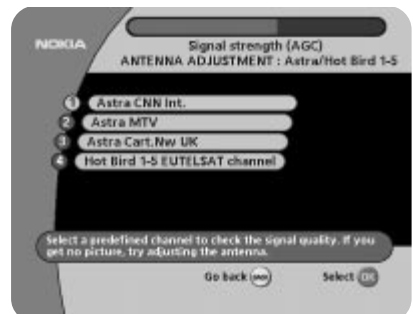

# FIRST TIME INSTALLATION

## Line 7 on the Antenna Satellite Selection Menu

This selection is necessary **only if your satellite choice differs** from the preprogrammed satellite alternatives in the following ways; if you do not use a universal LNB or when you have more than two LNB's.

### One Antenna/One LNB Configuration

Select this alternative if you have **one LNB** mounted on the antenna and you want to select another, not preprogrammed, satellite.

### Switch type and port

The "None" alternative is preselected and cannot be changed.

### LNB Type

Select the local oscillator (L. O.) frequency valid for the present LNB. The most common values, including Universal LNB, are selectable with the ◀ ▶ buttons.

You can also enter a value with the numeric buttons when the symbol for the remote control is visible on the line.

### LNB Offset voltage

If the cable down from the antenna is very long, the voltage at the LNB could be too low to change the polarization. You can increase the voltage to the LNB by 0,5 V.

### Satellite

Select one of the preprogrammed satellites.

### Predefined Channel

Select one of the preprogrammed channels and adjust your antenna according to the **"Antenna Adjustment and Signal Check"** section on page 14.

When you then press **OK** to start searching for channels, you will get the "Channel Search" menu described on page 18.

From that menu, select Automatic or Manual Search.

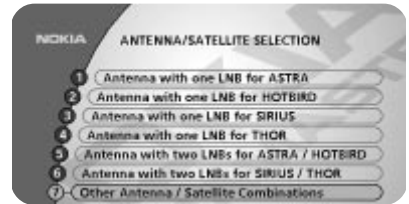

OK

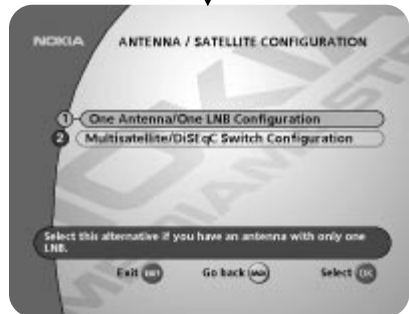

OK

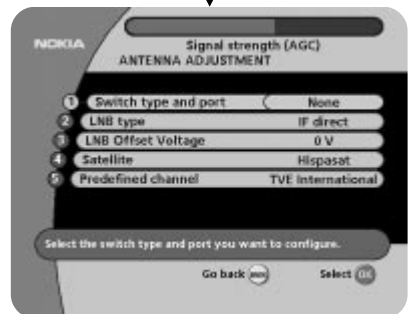

OK

Please follow the procedure described on page 14.

# FIRST TIME INSTALLATION

## Multisatellite/DiSEqC Switch Configuration

Select this alternative if your antenna system **has more than one LNB**.

You can connect up to 4 LNBs. The selection of the different LNBs must be controlled by an external switch. Refer to page 15, "Connection of a DiSEqC switch."

**For each LNB and switch port, you will have to specify the following:**

### Switch type and port

With more than one LNB you must use an external "DiSEqC" or a "Mini DiSEqC" switch. Select from the preprogrammed alternatives for the valid type in your configuration.

Mini A and Mini B are intended for a "tone burst" switch.

### LNB Type

Select the local oscillator (L. O.) frequency valid for the present LNB. Refer to page 16.

### LNB Offset voltage

If the cable down from any of the LNB's is very long, it might be necessary to increase the voltage to these LNB's by 0,5 V.

Increase the voltage

- a. only if a LNB does not change polarization
- b. only to the specific LNB mentioned in a. above

### Satellite

Select one of the preprogrammed satellites.

### Predefined Channel

Select one of the preprogrammed channels.

Next, follow the instructions on page 14, "Antenna Adjustment and Signal Check."

When you press **OK** to start searching for channels, you will activate the Channel Search menu described on page 18.

From that menu, select Automatic or Manual Search.

After each channel search you will get a message asking if you want to make a new channel search on another LNB, or stop the search procedure.



OK

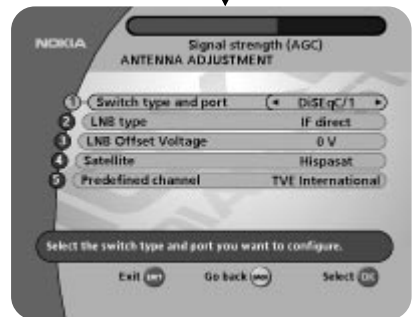

# FIRST TIME INSTALLATION

## Channel Search

The Channel Search procedure can be performed in different ways.

- If there are predefined channels, you can make an “Automatic” or “Manual Search.”
- If no predefined channel is available you can only perform a “Manual Search.”

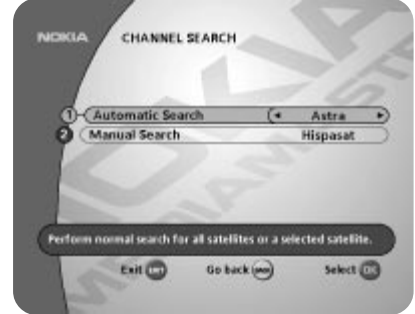

### Automatic Search

Start an Automatic Search on a selected satellite by pressing **OK**.

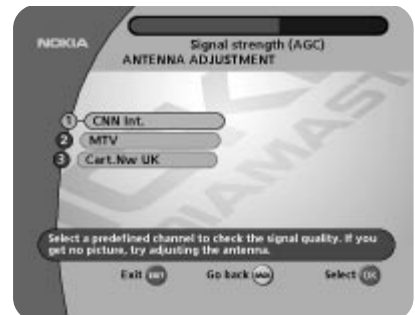

### Manual Search

When you perform a Manual Search you first need to enter some parameters for the channel search to work.

The information you need to enter in this menu is available in magazines covering satellite TV reception, on the Internet or from your Service Provider.

**Transponder frequency:** Specify the frequency in GHz. If you enter the wrong figure(s), erase with the ◀ button.

**Polarization:** Select Horizontal, Vertical, Circular left or Circular right.

**Symbol rate (MSym/s):** Enter with the numeric buttons. If you enter the wrong figure(s), erase with the ◀ button.

**FEC:** Select “Auto” or any of the preprogrammed values.

**Network Search:** Select “Yes” if you want to search on all transponders connected to a specific network.

Press **OK** to start searching for channels.

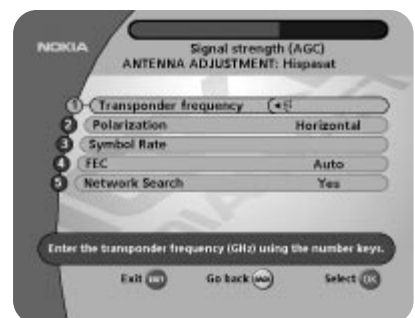

# FIRST TIME INSTALLATION

## Channel Search Progress

In the Channel Search Progress Menu, you can start searching for digital channels offered by the satellite for which your antenna has been configured.

All channels found will be listed in two columns on the screen; with TV channels in one column and Radio channels in the other.

Please note that the search procedure may take a few minutes.

When the search procedure has ended, the screen will show how many TV and Radio channels have been found.

Press **OK** to go to the Time Adjustment menu.

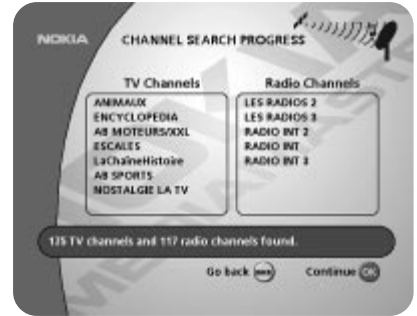

## Time Adjustment

The time is adjusted by using the ▼ ▲ buttons,  $\pm 1/2$  an hour at a time.

You can also adjust the minutes by using the ◀ ▶ buttons.

Press **OK** and you are ready to watch TV.



# VIEWING MODE

## General Information

The following describes the basic functions of your Mediamaster while watching satellite TV or listening to satellite radio.

**Some of the functions described here are dependent on the Service Provider and can only be used if they are included in the transmitted programme information.**

**Please note**, that during the Channel Search procedure, the Mediamaster may download a large number of channels. This may include channels from various Service Providers, also those to which you do not have access unless you have a Smartcard from one of those Service Providers.

If you select a programme to which you do not have access, you will get a message on the screen. This message may vary, depending on Service Provider and used Smartcard/CA Module.

While viewing, the current channel number will be shown on the front panel display.

In addition to the normal functions like switching the Mediamaster in/out of stand-by, changing the volume etc. (ref. to the overview of the remote control) there are some other useful functions which will be explained in this part of the manual.

## Programme Information

Every time you change channels you will receive programme information for a few seconds. (In the "User Preferences" menu you can select how long this information will be shown.)

The information may include:

Current time.

Channel list.

Channel number and name.

Name of the current and next programme.

The start and total time of the current programme.

A bar, indicating the elapsed time of the current programme.

Recommended lowest age limit for watching the programme.

The start and total time of the next programme.

Programme information will only be available if it is included in the transmission. Otherwise a "No information available" message will be shown.

You may change channel lists with the ◀▶ buttons.

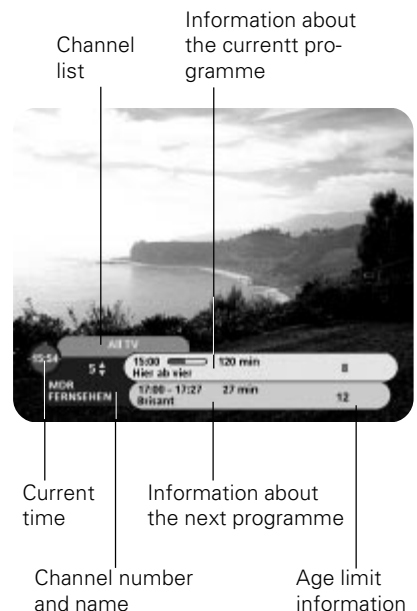

# VIEWING MODE

## The "i" (Information) Button

The Mediamaster has the ability to display information about programmes currently being broadcast as well as those being broadcast next.

This procedure is the same for both TV and Radio mode.

By pressing the "i" button while watching TV you will get a special Programme Information Banner. Select channel with ▼ ▲ or the numeric buttons.

The "i" symbol is coloured blue when displaying information about the current channel, and red when information for another channel is shown.

Press "i" again to get more information about the current programme.

If a lot of information is available you can use the double arrow button to see the rest of the text.

Press "i" a third time to return to TV/Radio mode.



In this view, you can select to get information about the current and next programme by using the ◀ ▶ buttons.

You can leave the menus at any time and return to viewing TV by pressing **EXIT**.



## Guide

By pressing the **GUIDE** button you get access to the **TV Guide** (or Radio Guide if you are listening to radio channels) which will give the titles of the current and next programmes on different channels. The information is only available from the network (e.g. DF1, TPS) to which the channel you are watching belongs.

Use the ▼ ▲ buttons to move the cursor to another programme. Use the double arrow buttons to move a page at a time up and down.

When a line is highlighted, you can get more information about this programme by pressing the "i" button.

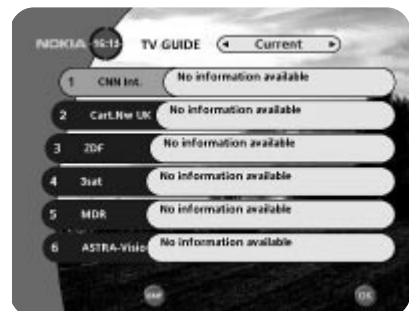

# VIEWING MODE

## List of TV or Radio Channels

When viewing TV or listening to radio channels you can access the Channel List by pressing **OK**. The lists are sorted by satellite, network and channel.

At the top of the menu you will see the name of the list. The current list is the one in which the channel you are watching right now is located.

- If the list contains a large number of channels, you can close satellites or networks to reduce the number of channels. You open/close a satellite or network by marking it and pressing **OK**. A closed satellite/network is indicated with .

Change channel lists with **Left Arrow** **Right Arrow**.

To open the radio channel list you first have to enter radio mode by pressing **"EXIT TV 🎵"** and then **OK**.

You can change channel by stepping with the **Down Arrow** **Up Arrow** buttons or enter the channel number with the numeric buttons on the remote control.

Press **OK** when a channel name is highlighted to start watching/listening to it.

To change one channel list page at a time, use the **double arrow** buttons.

You can also get more information about a marked (highlighted) channel by pressing the **"i"** button.

Scrambled channels are marked with a picture of a Smartcard.

Name of the Channel list      Indicates a closed satellite



Channel name      Network name

## Options (Green Button)

By pressing the **OPTION** button, you open a menu in which it is possible to enter **temporary** settings. The menu will only appear if the programme contains any options to change.

Settings made in this "options menu" are only valid for the programme you currently are watching. If you leave the programme and return to it again, the temporary settings will be gone.

### Audio Language

If available, you can select among the different languages being broadcast.

### Subtitle Language

If available, you can select among different subtitle languages. If you select "OFF", you will not get any subtitling at all.

### Format

If you have a TV set with a 4:3 picture format, and the transmission is in 16:9, you can select Fullscreen or Letterbox to change display format.

Fullscreen will fill up the screen vertically, but cut off some information from the left and right sides of the picture.

Letterbox will give a complete picture, but leave black areas at the top and bottom.



# VIEWING MODE

## TV Release (0)

With the **0** button you can toggle between analogue terrestrial TV, video, analogue and digital satellite TV signals. (This is only valid if the units are connected via SCART cables, and not by a RF connection.)

## Video Recording

Please note, that during the recording of a programme, **everything** shown on the screen will be registered! For example, if you call up a menu from the Mediamaster on the screen, the menu will be recorded!

## The TEXT Button (Teletext)

Pressing the **TEXT** button will open a Teletext page (if Teletext is transmitted.) Select teletext pages with the numeric buttons on the remote control.

You can also quickly step to the different page alternatives shown in any page by pressing ◀ ▶. Press **OK** on a selected number to go to that page.

Press **EXIT**, **BACK** or **TEXT** to return to TV/Radio mode.

The "0" button will show the index page (normally page 100.)

▲ ▼ will show the next or previous teletext page.

You can use the **double arrow** buttons to browse through the pages you just have visited.

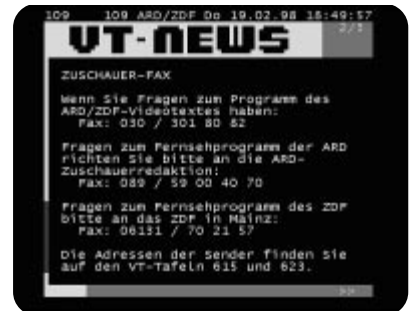

## EXIT TV 🎵

This button has double functions.

While watching TV: The **TV/🎵** function is used to switch from TV to Radio mode and vice versa.

When you have entered a menu, the **EXIT** function is used to leave the menu at any time without changing anything.

# MAIN MENU

## General Information

Many of the functions of the Mediamaster are available from the Main Menu. Press **MENU** to open it.



## TV and Radio Channels

Please refer to “List of TV and Radio channels” on page 22.

## Edit Channels

From these menus you can create and edit channel lists. You can, among other things, create favourite lists; add, delete, rename and arrange the order of the channels within the lists.

In the “All TV” list the channels are presented satellite by satellite starting with the name of the satellite, followed by the name of the distributor, also called the Network Identifier (ID.) Examples of Network ID:s are DF1 and Canal+.

The “All TV” list can contain hundreds of channels. By creating your own favourite lists you can make channel handling a bit more convenient.



### Important when editing channels!

Changes in the Edit Channels menus always take immediate effect; it is not possible to cancel changes by pressing **BACK**!

# MAIN MENU

## Create list

From here you can create your own favourite lists, containing the channels you watch most frequently. You can give each list a specific name, e.g. "Sport" or "Films."

When a favourite list is selected, you see only those channels defined in the list.

When you have given the list a name; press **OK** and you will enter the "Select Channels" menu (see next page) from where you add channels to the list.

You can create separate favourite lists for TV and Radio channels.

## How to give a specific name

This procedure is the same whether you enter a name for the first time or change an existing.

- Move to a new character position by using ►.
- To delete the last character use ◀.
- Enter the characters one by one (A...Z, 0...9) by using ▼ ▲. To speed up the procedure a bit you can use the double arrow buttons to jump 3 letters at the time.
- Figures can also be entered with the numeric buttons on the remote control.
- The next letter will be shown above the current, and the previous below it.
- Toggle between capital and lowercase letters with the **blue button**.

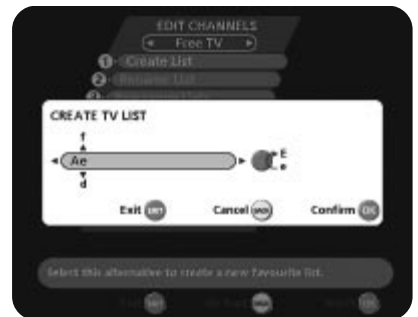

## Rename list

From here you can give an existing list a new name. Use the arrow buttons the same way as when you created the list.

## Reorder lists

If you have created several Favourite lists you can determine the sequence in which the lists will appear.

## Delete list

If you want to delete a Favourite list completely, select the list and press **OK**.

# MAIN MENU

## Select Channels

From this menu you add and remove the channels in your Favourite Lists. You use the "All TV" or "All Radio" list as basis to select the channels from.

A channel is added or removed by pressing the **OK** button. The square to the right on a line will be empty for removed channels, and will contain an "x" for added channels.

- If you have a Favourite list that contains several satellites and networks, you can close the one(s) you are not going to work with. You open/close a satellite or network by first marking it and then pressing .

A closed satellite/network is indicated with  on the line.

- Move to desired channel(s) with **▼ ▲**, double arrows or the numeric buttons, and add/remove them by pressing **OK**.
- When you are ready, confirm the selections and leave the menu by pressing **BACK** or **EXIT**.



## Lock Channels

To get to this menu you first have to enter your access code.

From here you can lock (and later unlock) channels in any of the lists in order to prevent e.g. your children from watching.

Select the channel you want to lock and press **OK**. Repeat the procedure for each channel you want to lock. When you lock a channel in any list, the channel will automatically be locked in all other lists.

A locked channel will be marked with a padlock symbol.

When watching TV, you will be asked to enter your access code before you can watch a locked channel.

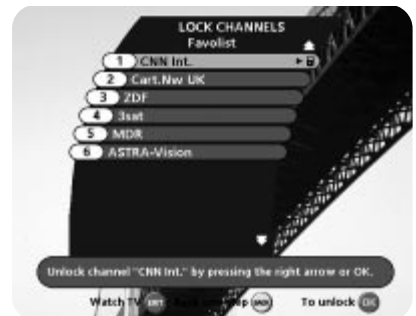

# MAIN MENU

## Rename Channels

Within any of your favourite lists you can rename the channels. Mark the channel you want to rename and press **OK**. The Rename dialogue box will then appear and let you modify the existing name.

To enter the new name, please follow the instructions under the headline "**How to give a specific name**" on page 25.

When you have changed a channel name, the new name will appear in all lists where the channel is included.



## Rearrange Channels

From here you can arrange the sequence for the channels within your favourite lists.

- With **▶**, mark the channel you want to move to a new position within the list.
- Press **▶** again and the right side of the marked channel will change to **▼ ▲**.
- Move the channel to the desired position with **▼ ▲** and press **OK**.

It is also possible to first mark several channels, and then move them all simultaneously.

- For each channel, press the **▶** button to add it to the set of marked channels.
- When a number of channels are marked this way and you want to move the whole set of channels, press **▶** again.
- The marked channels will now be put together into one group.
- The right side of the first and last marked channel will change to **▲ ▼** arrows respectively.
- Use the corresponding buttons to move the selected channels to a new position within the list.
- When the channels are in the position you want, press **OK**.

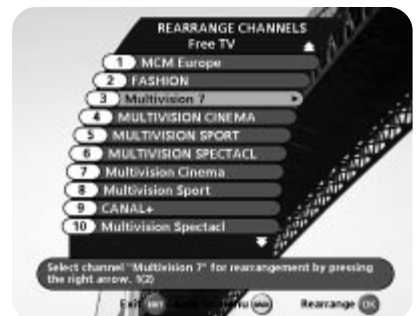

# MAIN MENU

## Delete Channels

From here, when the **"All TV" list** is selected in the "Edit Channels" menu, you can delete channels.

**Please note. Channels deleted this way will be permanently deleted. The only way to get them back is to perform a new channel search.**

### To delete channels:

Mark the channel you want to delete and press **OK**. You will be asked if you really want to delete it. If so, confirm by pressing **OK** once more. If not, press **BACK**.

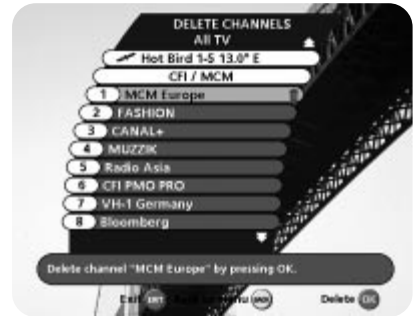

## Remove Channels

From here, when the **"Free TV" or a favourite list** is selected in the "Edit Channels" menu, you can remove channels from those lists.

### To remove channels:

Mark the channel you want to remove and press **OK**. You will be asked if you really want to remove it. If so, confirm by pressing **OK** once more. If not, press **BACK**.

Channels removed from a list this way are **not** permanently deleted. They are still available from the "All TV" list.

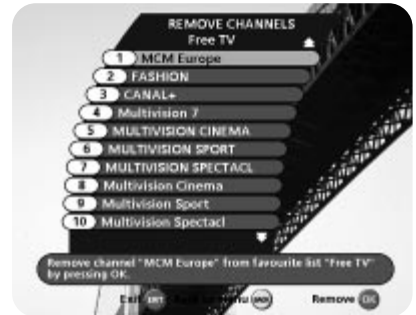

# MAIN MENU

## System Configuration

You will be asked to enter your access code before you can open this menu. The code is preset to 1234 from the factory. (The code can be changed from the Parental Control menu. Refer to page 32.)

If you want to customize the system to suit you better, you can specify some settings from the submenus in the "System Configuration" menu.

Please note that many of these functions are the same as in the "First Time Installation."

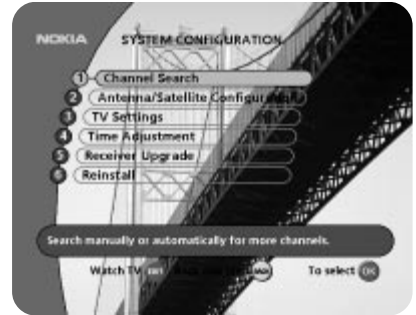

## Channel Search

The Channel Search procedure can be performed in different ways. You can perform an Automatic or a Manual Search.

### Automatic Search

Refer to page 18.

### Manual Search

Refer to page 18.



## Antenna/Satellite Configuration

The procedure is the same as performed during the First Time Installation. Please refer to page 16.

Only your current Antenna/Satellite configuration alternative will be selectable. Other alternatives will be dimmed.



# MAIN MENU

## TV Settings

From here you can adjust settings concerning your TV.

### TV screen format

Select your TV screen format.

The 4:3 format is the standard format for most TV screens. Select 16:9 for a wide screen TV.

### TV signal

If the teletext function does not work when watching channels from an analogue satellite receiver connected to the Mediamaster, change this setting from RGB to PAL.

### RF channel

Select this alternative if you have to change the RF channel. If you change the RF channel number, you must also change it to the same value on the TV. If you do not, the picture will become black.

### RF Channel fine tune

If necessary, you can fine tune the RF channel for better result.

### RF modulator type

If the Mediamaster is connected to the TV by an RF lead, you can select the RF modulator type. The RF Modulator affects a channel's audio. If you get picture but no sound, the RF modulator selection might be wrong.

Select **UK (PAL I)** if the Mediamaster is used in the UK.

Select **Other** if it is used elsewhere.

### Position of the RGB output

Adjust the horizontal position of the TV picture with the ◀ ▶ buttons. (The "TV signal," see above, must be set to RGB for this function to work.)

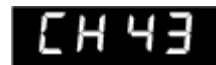
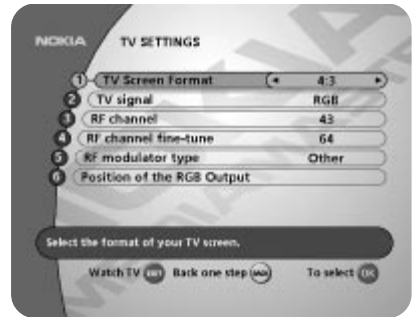

The RF channel number will be indicated on the front display of the Mediamaster.

## Time Adjustment

The time is adjusted by using the ▼ ▲ buttons, ±1/2 an hour at a time.

You can also adjust the minutes by using the ◀ ▶ buttons.



# MAIN MENU

## Receiver Upgrade

In order to keep the Mediamaster up-to-date, it will be possible to download new versions of the system software via satellite (THOR) and from the Internet. New software may include new or improved features for existing menus.

Enter this menu to check for new software. If new software is available you will get information in the menu on how to proceed. If you download new software from the Internet, you transfer the software from the computer to the Mediamaster via the serial port.

**IMPORTANT!** Updating via satellite may take a while. The front display will indicate the percent left to download.

**NEVER turn off the Mediamaster or disconnect the antenna/LNB cable during the download procedure! This will damage the software and the receiver will have to be sent in for service!**



## Reinstall

Use this option **only** if you have to start the complete installation procedure from scratch. If you continue from here, **all** your previous settings, parental code and favourite channels etc. will be erased!

**If you do not want to change any settings you can leave this menu when the warning is displayed by pressing BACK or EXIT.**

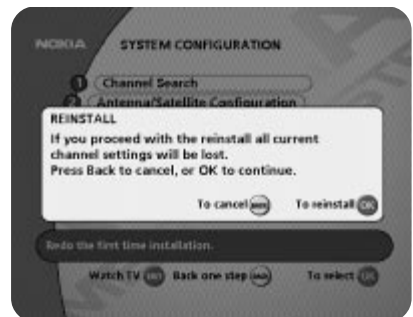

## User Preferences

From here you can change the menu language. You also have access to the Parental Control and the Appearance menus.

## Language Preferences

### Menu Language

Here you may select which language the menus will be shown in.

### Main and Alternative audio language

If more than one audio language is transmitted, you may select the main and an alternative language.

### Subtitles

If you select the "Visible" alternative for subtitling and more than one language is available, you may select a main language and an alternative.

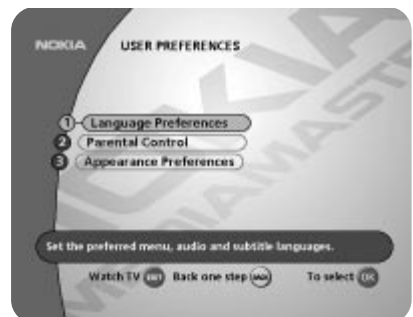

# MAIN MENU

## Parental Control

To open this menu you will be asked to enter your access code. **From the factory the access code is set to 1234.**

The following settings can be altered from this menu.

### Receiver lock

If you select "On," you will have to enter the access code every time you start the Mediamaster from stand-by.

### Age Rating Control

If you want everybody to have access to all available types of programmes, select "Off."

If you select "On," you may block programmes unsuitable for children. Select an age limit between 4 and 18 years on the line that appears.

However, you should be aware that not all Service Providers have the necessary codes for these functions implemented in their transmissions.

### Change access code

**From here you can change the access code from the standard 1234. DO NOT FORGET IT! Without it you do not have access to any of the functions where the code is required! If you forget it, you have to contact an Authorized Nokia Service Center to get help.**

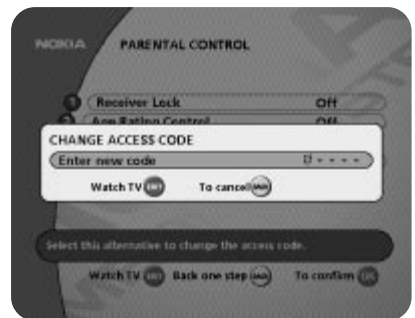
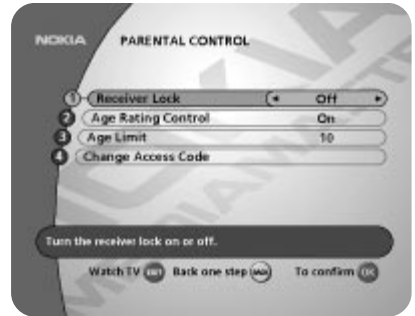

## Appearance Preferences

### Banner time-out

When you switch channels, an information banner will be shown for a few seconds. You can select for how long the banner will be shown.

### Volume bar

Select whether or not you want the volume bar to appear on the screen when you change the volume.

### Volume bar time-out

Select how long the banner will be visible on the screen.

### Subtitles

Select whether or not subtitles will be visible on the screen.



# MAIN MENU

## Picture format

If you have a TV set with the 4:3 picture format and the transmission is in 16:9, you can select Fullscreen or Letterbox.

Fullscreen will fill up the screen but cut off some information on the left and right sides.

Letterbox will give a complete picture, but leave black areas at the top and bottom.



'letterbox format'



'fullscreen format'

## System Information

If you have to contact your service provider or a service center, they might ask for information available from this menu. Therefore, it is important that you first check the information in the following menus.



## System Information

This gives general information about which hardware and software version your Mediamaster is running on.

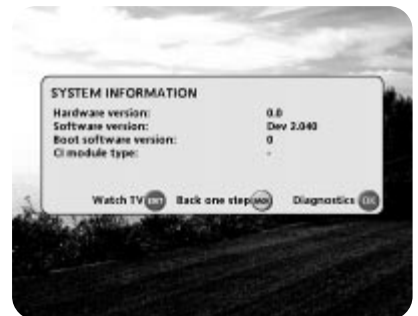

## Diagnostics

To find out the condition of certain parts of the Mediamaster, you can run a diagnostic test.

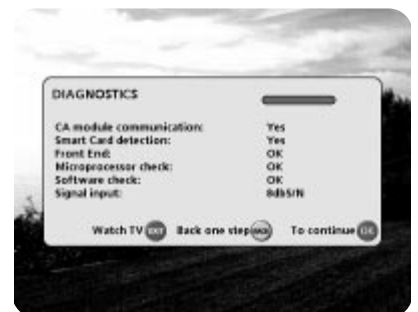

# MAIN MENU

## Conditional Access

This menu will only be activated if you have inserted a valid Smartcard in the slot behind the front lid.

If more than one CA system is activated, select the one from which you want information.

The Viaccess Conditional Access (CA) System is embedded in the Mediamaster. A Smartcard that supports this standard can be used in the left slot on the front panel.

Different CA modules (with their Smartcards) supporting the DVB Common Interface (CI) standard can be used in the right slot.

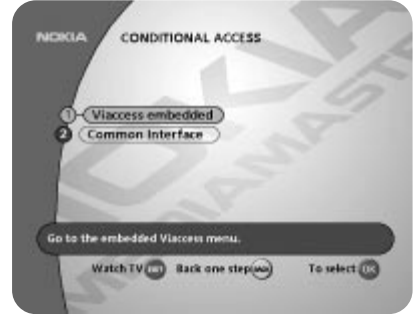

### Viaccess embedded

From here you get subscription information from a Smartcard supplied by a Viaccess Service Provider.

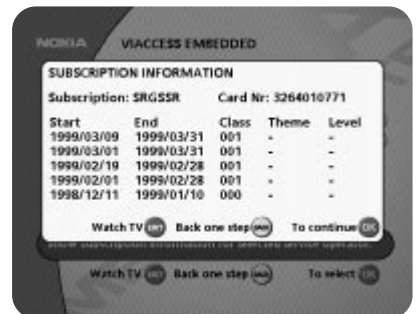
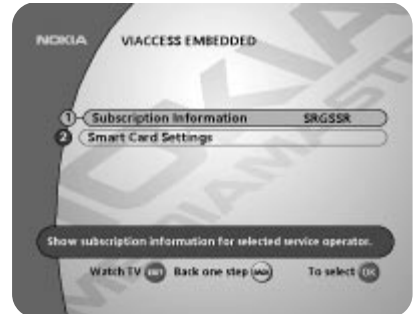

### Common Interface (CI)

This leads to the menus provided by the CA Module and its Smartcard.



# GLOSSARY OF TERMS

## **Access**

Authorisation to use the coding system to purchase / order TV programmes.

## **AGC**

Acquisition Gain Control.

## **Audio system**

With digital satellite reception, the sound is transmitted in packages and is selected either in a special audio mode or pre-selected by using the installation set-up. This makes it possible to select between several different languages in a film. The number of choices is dependent on what is available in the signal.

## **CA**

Conditional Access. A system to control subscriber access to services, programmes and events.

## **CA module**

A device for the decoding of scrambled signals.

## **Common Interface**

Describes a DVB standard hardware and software architecture for Conditional Access systems.

## **DVB**

The Digital Video Broadcast group was created to establish a technical framework for the introduction of digital video broadcasting systems.

## **EPG**

Electronic Programme Guide. A software that enables viewers to navigate easily among the large number of channels provided by digital technology, in order to select the service they desire.

## **FEC**

Forward Error Correction. Correction of faulty bits in the received signal.

## **GHz**

The prefix giga means billion, and Hertz means cycles per second. Signals in the GHz range are often called microwaves.

## **LNB (low-noise block converter) or LNBF**

An electronic unit mounted on the satellite dish. It receives the signals reflected by the dish and converts them to signals that can be used by the Mediamaster.

## **L.O.**

Local oscillator part of the LNB. It converts from the satellite frequency down to a frequency acceptable for the Mediamaster.

## **Mediamaster**

A unit that converts the digital satellite signals into audio and video signals. The audio and video signal can be sent to the TV set either via SCART or via RF (modulator output).

## **MHz**

The prefix mega means million, and Hertz means cycles per second.

## **MPEG**

Moving Picture Experts Group. Body established by the International Standards Organisation to provide the basis for a picture coding and compression system.

## **Network**

A number of digital channels transmitted from one source. Grouped under separate headings in the channel list.

## **Parental control**

A feature that allows parents to "lock" programmes that they consider unsuitable for children. A "locked" channel or programme can only be "unlocked" with the special parental access code.

## **Parental Access code**

A four-digit code stored in the Mediamaster. Used to lock the Mediamaster.

## **PCMCIA**

Personal Computer Memory Card International Association. The Common Interface slot follows this standard.

## **PCR**

Program Clock Reference.

## **PIN code**

Personal Identification Number. A four-digit code stored in the Smartcard. For PPV (Pay Per View) or other services together with the subscription.

## **Polarization**

Polarization allows several programmes to be fit into the same frequency band. The signals from a satellite are transmitted either with linear (vertical or horizontal) polarization or circular (right or left) polarization.

## **RF**

Radio frequency (known as HF in some countries).

## **SERIAL RS 232**

A serial communication standard data port.

## **Satellite dish**

A dish-shaped antenna (reflector) to receive signals from a satellite. The dish focuses the signals into the LNB.

## **SCART**

A 21-pin connector used for connection of the Mediamaster, VCR and TV. Also named Euroconnector or Peritel connector.

## **Scrambled satellite TV programme**

Some satellite TV programmes are transmitted in scrambled form. A Smartcard, and possibly a CA module, will be needed to view such programmes.

## **Service provider**

Is a company that collects a number of programmes/services and distributes them to customers.

## **SNR**

Signal to Noise Ratio. Signal quality measure.

## **S/PDIF**

Sony/Philips digital interface format. Digital audio output.

## **Symbol rate**

Size of the digital package transmission

## **SW**

Software. Programme code.

## **TS**

Transport stream.

## **VCR**

Video Cassette Recorder.

# PROBLEM SOLVING

<b>Problem</b>	<b>Possible causes</b>	<b>What to do</b>
The display on the front panel does not light up/is not lit.	Mains cable is not connected.	Check that the mains cable is plugged into the power socket.
No sound or picture, but the front panel shows the time or -- : --.	The Mediamaster is in standby mode.	Press the standby button or any number button to bring the Mediamaster out of standby mode.
No sound or picture.	The satellite dish is not pointing at the satellite.	Adjust the dish. Check the signal level indicator in one of the channel search submenus.
	No signal or weak signal.	Check the cable connections, LNB and other equipment connected between the LNB and the receiver, or adjust the dish.
No sound or picture on horizontal modulated transponder.	The LNB is faulty.	Replace the LNB. Increase the LNB voltage with 0,5 V from the System Configuration menu if you have a long cable.
Bad picture/blocking error.	The satellite dish is not pointing at the satellite.	Adjust the dish.
	Signal too strong.	Connect a signal attenuator to the LNB input.
	Satellite dish is too small. LNB noise factor too high.	Change to a larger dish. Change to an LNB with lower noise factor.
	The LNB is faulty.	Change the LNB.
There is no Welcome menu on the screen after you switched on the Mediamaster for the first time.	The system is connected by SCART leads and the TV is not in AV/EXT mode. The system is connected by RF leads and the TV is not set to the channel tuned for digital satellite TV.	If the system is connected by SCART leads, switch the TV to the appropriate AV input. If the system is connected by RF leads, switch the TV to the channel for digital satellite TV. If you have not tuned in the TV you may do this first. Please look in the TV manual for instructions. You can also change the RF-channel in the Mediamaster. See TV settings.
There is interference on your digital satellite channels, an existing terrestrial channel or video signal.	The system is connected by RF leads and the output channel of the Mediamaster interferes with an existing terrestrial channel or video signal.	Change the Mediamaster output channel to a more suitable channel between 21-69, or connect the system by SCART leads.
You made a video recording of a digital satellite channel and whole or parts of the programme was not recorded.	The Mediamaster was not left on the appropriate channel.  The system is connected by SCART leads and the VCR is not in AV/EXT mode. The system is connected by RF leads and the VCR is not set to the channel tuned for digital satellite TV.	If you make a recording of digital satellite TV your Mediamaster has to be left on the channel you want to record. If the system is connected by SCART leads, switch the VCR to appropriate AV input. If the system is connected by RF leads, switch the VCR to the channel for digital satellite TV. If you have not tuned in the VCR you may do this first. Please look in the VCR manual for instructions.

## PROBLEM SOLVING

Problem	Possible causes	What to do
The remote control is not working.	Battery exhausted. Remote control is incorrectly aimed.	Change the batteries (both). Aim the remote control at box. Check that nothing blocks the front panel.
	The Mediamaster is in standby mode.	Check if (.) is flashing on the front panel display when you press a button. If not replace the batteries (both).
You see the on-screen message. Viewing card error.	The Mediamaster can't recognise your Smartcard.	Check that you are using the proper Smartcard. Check that the Smartcard has been correctly inserted. If the problem persists, you may have a problem with the card. Contact your dealer or Service Provider.
You have forgotten your secret PIN code.		Contact your Service Provider. They will help you set it up again.
CA Module is not working.	CA module is not installed. CA module is not correctly inserted.	Check that the CA module has been correctly inserted. Contact your dealer or Service Provider.

**Please note:** The first thing to do before sending the Mediamaster to service is to:

1: Perform "Diagnostic" procedure in System Information menu.

2: Try downloading new software into the Mediamaster.

With this procedure, the new software may solve the problem in the quickest and most efficient way. See the relevant section "Receiver Upgrade" earlier on in this manual.

### What to do if you can't solve the problem

If you have tried all of the actions suggested above, without solving the problem, please contact your dealer or Service Provider.

## FRONT PANEL DISPLAY

9800	When power-up, boot version, product family and system software version is shown.	Eu	In TV mode.
EU1 .2	When starting from standby, product variant and system software version is shown.	uCr	In video mode.
50	Remaining time in percent during the download procedure.	od1	When downloading new software via the air.
08 :30	The Mediamaster is in standby mode, and current time is shown.	Sd1	When downloading new software via the Serial RS232 socket.
1 30	Channel number in TV mode.	E1 23	Error messages. For service personnel
A1 30	Channel number in radio mode.	.	Lights when no signal is being received.
CH 43	RF channel in tuning mode.	.	Flashes when pressing a button on the remote control.

# TECHNICAL SPECIFICATIONS

## Transmission Standards

DVB, MPEG 2

## LNB / Tuner input

Connector 1x F-type (LNB)  
 RF input frequency 920-2150 MHz  
 RF input power level -20 to -70 dBm  
 Supply voltage 13,5 / 18,5 V  $\pm$  5%  
 Max. current 500 mA, overload protected  
 Control voltage 22 kHz, 0,65 V<sub>pp</sub>  
 DiSEqC Tone burst A/B or Level 1.2  
 RF impedance 75  $\Omega$

## RF modulator

Input/output connector IEC female / IEC male  
 Modulator frequency 470 to 862 MHz  
 Output level 70  $\pm$  5dBV  
 Output channel 21-69  
 Preset channel 43  
 Output signal PAL B/G or PAL I

## TV SCART

Video output 1 V<sub>pp</sub> ( $\pm$ 1 dB) / 75  $\Omega$   
 Audio output 0,5 V<sub>rms</sub> / R<sub>L</sub> >10 k $\Omega$   
 RGB output Internal RGB or from AUX SCART  
 RGB bandwidth 5,8 MHz  $\pm$  3 dB  
 Fast blanking output Internal or from AUX SCART  
 Status output 0/6/12 V / R<sub>L</sub> 10 k $\Omega$

## AUX SCART

Video output 1 V<sub>pp</sub> ( $\pm$ 1 dB) / 75  $\Omega$   
 Video input 1 V<sub>pp</sub> / 75  $\Omega$   
 Audio output 0,5 V<sub>rms</sub> / R<sub>L</sub> >10 k $\Omega$   
 Audio input 0,5 V<sub>rms</sub> / R<sub>L</sub> >10 k $\Omega$   
 Status input 0/6/12 V / R<sub>L</sub> >10 k $\Omega$   
 Fast blanking input 0/2 V for RGB, bypass to TV SCART  
 RGB input Yes

## DIGITAL AUDIO (S/PDIF)

Connector 1 x RCA

## AUDIO R L

Connector 2 x RCA (R+L)  
 Output 0,5 V<sub>rms</sub>  $\pm$  0,5 dB / R<sub>L</sub> 10 k $\Omega$

## SERIAL (RS 232) Serial data

Connector 9-pin D-sub male  
 Signals RS232, max. 115,2 kbit/s  
 Pin 1 DCD (Data carrier detect) not connected  
 2 RXD (Receive data)  
 3 TXD (Transmit data)  
 4 DTR (Data terminal ready) Set to high  
 5 GND (Signal ground)  
 6 DSR (Data set ready) not connected  
 7 RTS (Ready to send)  
 8 CTS (Clear to send)  
 9 RI (Ring indicator) not connected

## Conditional access system:

Embedded Viaccess and one PCMCIA interface for a Common Interface CA module (DVB Standard)

## Smartcard Interface:

Interface for one card according to ISO 7816  
 Supports embedded descrambler Viaccess

## Front panel

4x7 segment numeric LED display,  
 Buttons:  $\odot$ ,  $\blacktriangledown$ ,  $\blacktriangle$  (standby, progr. number up and down)

## General data

Article code The model code, variant and serial number, are located on a label on the underside of the housing.

Supply voltage 95-260 V AC, 50-60 Hz  
 Power consumption max 27 W at 500 mA LNB load  
 Power consumption in standby 5 W  
 Operating temperature +5° C to +45° C  
 Storage temperature - 40° C to +65° C  
 Humidity 25 to 90 % rel humidity  
 Operating distance for remote control max 10 meters  
 Dimensions (w x d x h) 380 x 240 x 65 mm  
 Weight 1,8 kg approx

## SCART-sockets

TV	AUX
1 Audio out right ch.	Audio out right ch.
2 -	Audio in right ch.
3 Audio out left ch.	Audio out left ch.
4 Audio ground	Audio ground
5 RGB blue ground	RGB blue ground
6 -	Audio in left ch.
7 RGB blue signal out	RGB blue signal in
8 Switch voltage out	Switch voltage in
9 RGB green ground	RGB green ground
10 Connect to pin 10 in AUX scart	
11 RGB green signal out	RGB green signal in
12 -	-
13 RGB red ground	RGB red ground
14 Fast blank. ground	Fast blank. ground
15 RGB red signal out	RGB red signal in
16 Fast blanking out	Fast blanking in
17 Video out ground	Video out ground
18 -	Video in ground
19 Video out	Video out
20 -	Video in
21 Ground (casing)	Ground (casing)



# MENUS SCREEN STRUCTURE

## First time installation

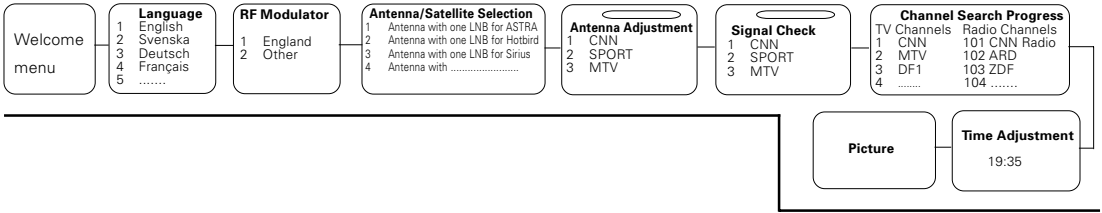

## Main Menu

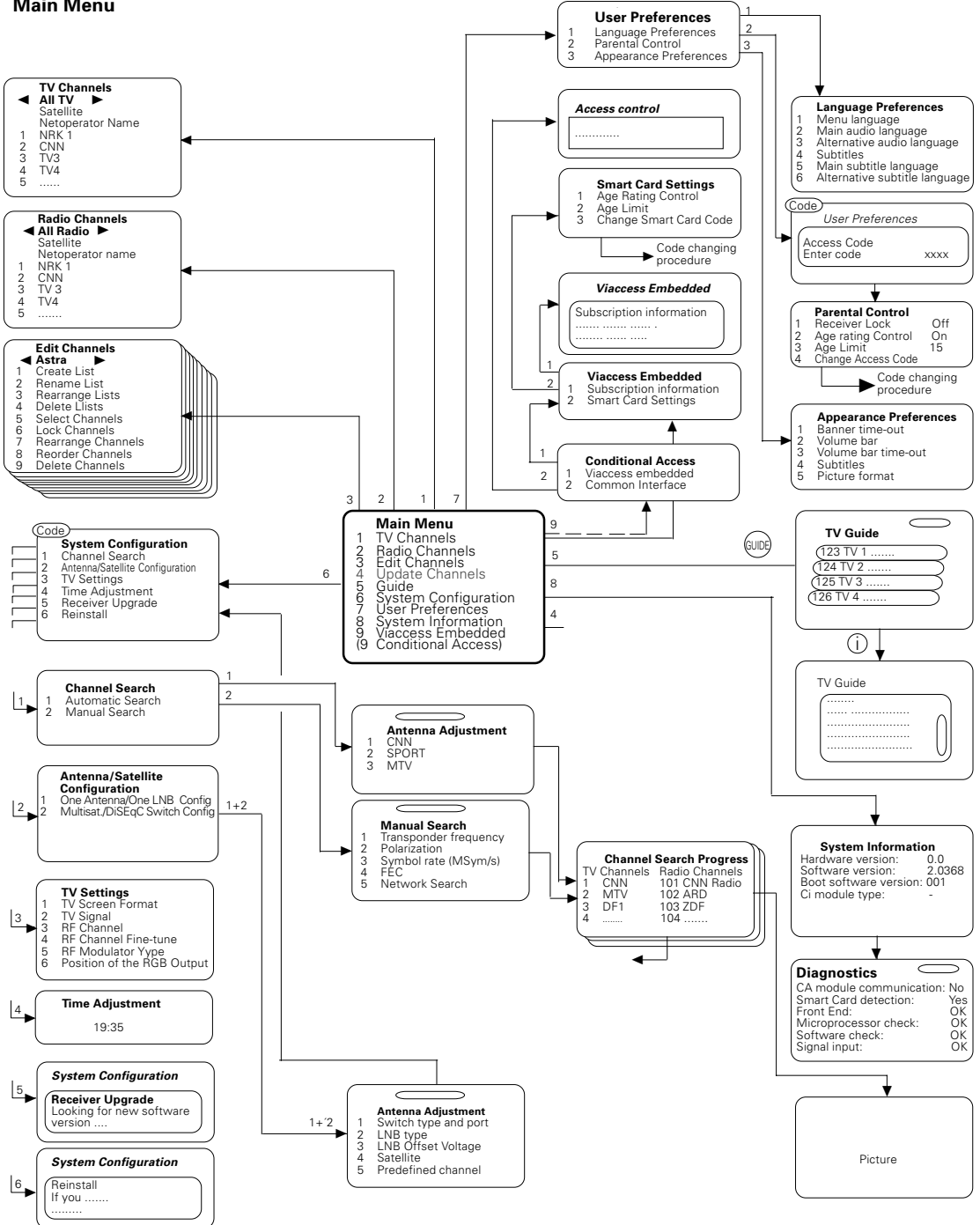

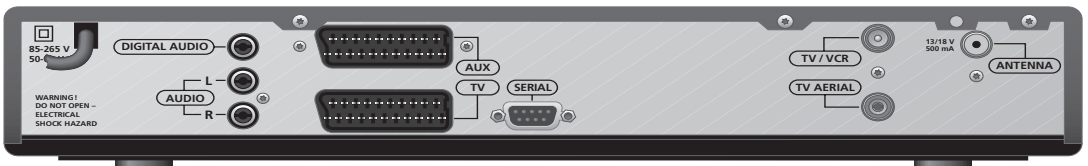

Nokia is a registered trademark of Nokia Corporation  
<http://www.nokia.com>

